

PIPE SIZE "U" BOLTS

FALCON FIG. F137* FROM STOCK

304 & 316 STAINLESS • PLAIN STEEL • STEEL ZINC & HOT DIPPED GALVANIZED

ALSO AVAILABLE

U-BOLT PLATES • SPECIAL DIMENSION U-BOLTS MADE QUICKLY

*Conforms to Federal Specifications WW-H-171E (Type 24) and Manufacturers Standardization Society SP-69 (Type 24)

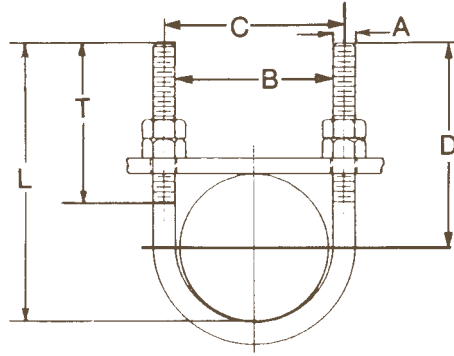

Pipe Size	Rod Size A	Inside Between Legs B	Center To Center Of Legs C	Tangent D	Thread Length T	Inside Depth L	Approximate Weight per 100		Maximum Rec. Load-Lb.
							No Nuts	W/4 Nuts	
1/2	1/4	15/16	1 3/16	2 3/4	2 1/8	3 7/32	7.4	10.3	485
3/4	1/4	1 1/8	1 3/8	2 3/4	2 1/8	3 5/16	7.6	10.3	485
1	1/4	1 3/8	1 5/8	2 3/4	2 1/8	3 7/16	8.1	11.0	485
1 1/4	3/8	1 11/16	2 1/16	2 7/8	2 1/8	3 23/32	22	28	1220
1 1/2	3/8	2	2 3/8	3	2 1/2	4	24	30	1220
2	3/8	2 7/16	2 13/16	3 1/4	2 1/2	4 15/32	26	32	1220
2 1/2	1/2	2 15/16	3 7/16	3 3/4	3	5 7/32	57	72	2260
3	1/2	3 9/16	4 1/16	4	3	5 25/32	64	79	2260
3 1/2	1/2	4 1/16	4 9/16	4 1/4	3	6 9/32	69	84	2260
4	1/2	4 9/16	5 1/16	4 1/2	3	6 25/32	75	90	2260
5	1/2	5 5/8	6 1/8	5	3	7 13/16	87	102	2260
6	5/8	6 3/4	7 3/8	6 1/8	3 3/4	9 1/2	167	196	3620
8	5/8	8 3/4	9 3/8	7 1/8	3 3/4	11 1/2	203	232	3620
10	3/4	10 7/8	11 5/8	8 3/8	4	13 13/16	365	413	5420
12	7/8	12 7/8	13 3/4	9 5/8	4 1/4	16 1/16	568	644	7540
14	7/8	14 1/8	15	10 1/4	4 1/4	17 5/16	613	689	7540
16	7/8	16 1/8	17	11 1/4	4 1/4	19 5/16	685	761	7540
18	1	18 1/8	19 1/8	12 5/8	4 3/4	21 11/16	1037	1150	9920
20	1	20 1/8	21 1/8	13 5/8	4 3/4	23 11/16	1133	1246	9920
24	1	24 1/8	25 1/8	15 5/8	4 3/4	28 11/16	1326	1439	9920
28	1	28 1/8	29 1/8	17 5/8	4 3/4	31 11/16	1506	1619	9920
30	1	30 1/8	31 1/8	18 5/8	4 3/4	34 11/16	1615	1728	9920
36	1	36 1/8	37 1/8	21 5/8	4 3/4	39 11/16	1904	2017	9920

**below 650° operating temperature



Falcon Metal
CORPORATION

Toll Free Nationwide 1-800-438-0332
Phone 704-588-4740 • FAX 704-588-5753

P.O. Box 7429 10715 John Price Road
Charlotte, NC 28241-7429 Charlotte, NC 28273
e-mail: info@falconmetal.com web: www.falconmetal.com